

Lab. 13

DESIGN AND CHARACTERIZATION OF FULL-DIFFERENTIAL OPA

1. Design of full-differential OPA

- Determine the sizes of the MOSFETs and fill in the blank of Table I.
 - The area and perimeter of MOFET are given by $W*3u$ and $W+6u$, respectively.

Target specifications

Parameter	Unit	Value	Remarks
GBP	Hz	40M	CL = 1.0pF
A_d	dB	100	@ 10Hz
Phase Margin	degree	60	
Slew Rate	V/us	10	CL = 1.0pF
Bias Current	A	200u	
Reference Current	A	10u	$I_{SS} = 20uA$

Table I

Folded-cascode differential amplifier

MOSFET	L(m)	W(m)	M	AD, AS(m ²)	PD, PS(m)	W/L
M1, M2						
M3, M4, M7-M10	2u	10u	3	30p	16u	15
M5, M6, M11-M13	2u	10u	1	30p	16u	5

The size of M1 and M2 can be estimated from the GBP and CL.

CMFB

MOSFET	L(m)	W(m)	M	AD, AS(m ²)	PD, PS(m)	W/L
M1-M4	2u	16u	8	48p	22u	64
M5-M12						
M13-M16	2u	10u	1	30p	16u	5

Remember that the CMFB circuit is a replica of the current source load of the amplifier.

Table II

BIAS

MOSFET	L(m)	W(m)	M	AD, AS(m ²)	PD, PS(m)	W/L
p-ch MOSFET	2u	10u	3	30p	16u	15
n-ch MOSFET	2u	10u	1	30p	16u	5

$$\Delta_{OV_p-ch} = \sqrt{\frac{2I_{DS}}{\beta_p}} = \sqrt{\frac{2 \cdot 10\mu A}{33\mu A/V^2 \cdot 15}} = 0.201V \quad \Delta_{OV_n-ch} = \sqrt{\frac{2I_{DS}}{\beta_n}} = \sqrt{\frac{2 \cdot 10\mu A}{98\mu A/V^2 \cdot 5}} = 0.202V$$

BMR

MOSFET	L(m)	W(m)	M	AD, AS(m ²)	PD, PS(m)	W/L
M1, M3, M4, M9, M10	2u	10u	1	30p	16u	5
M2	2u	10u	4	30p	16u	20
M5-M8	2u	10u	3	30p	16u	15
M11-M29	5u	5u	1	115p	11u	1

Folded cascode differential amplifier

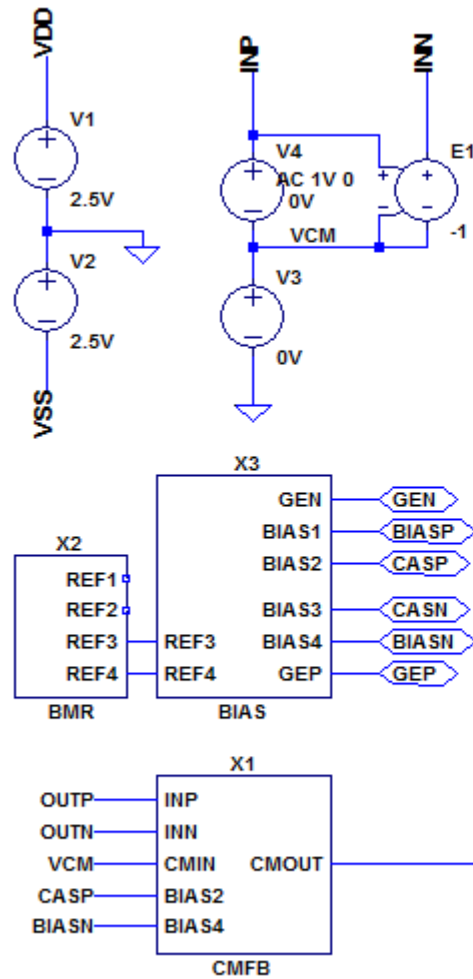

```

.lib cmos.lib
.global VDD VSS
.dc V4 -1mV 1mV 1uV ;ac dec 100 1Hz 10GHz ;tran 3us
  
```

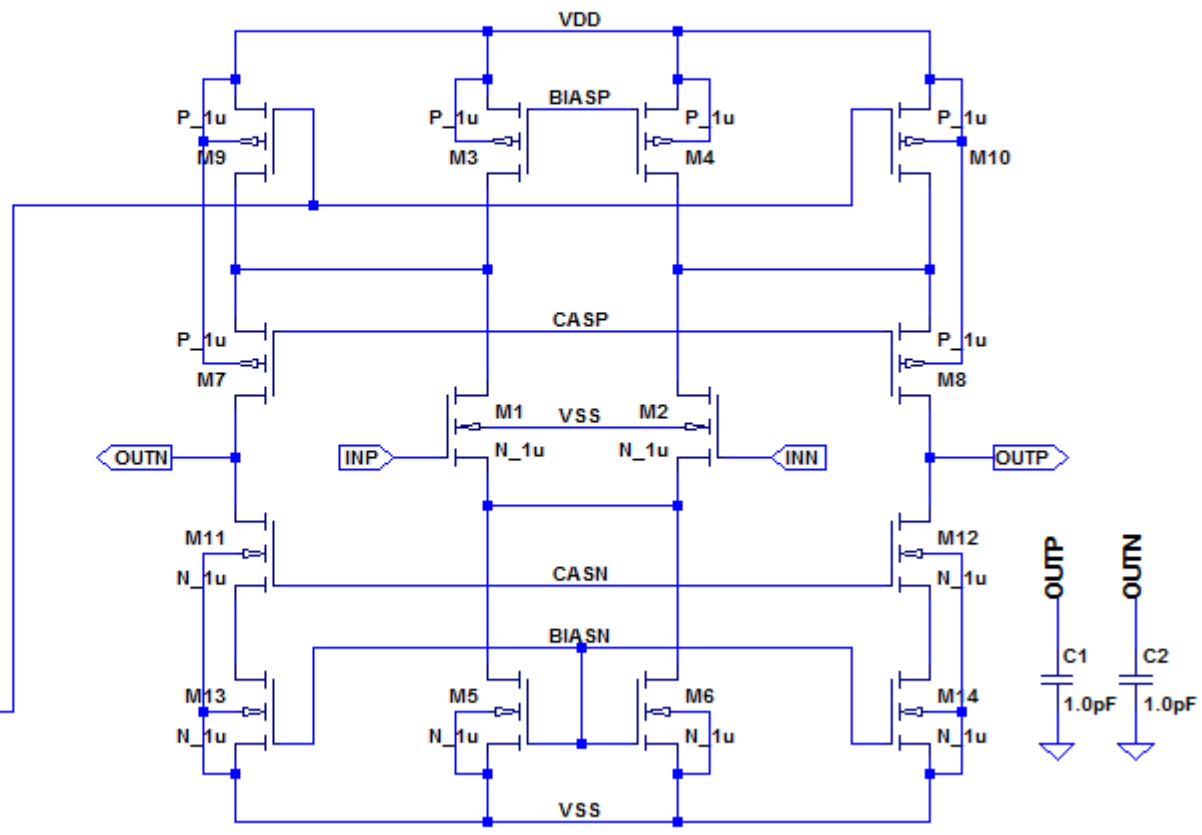

CMFB

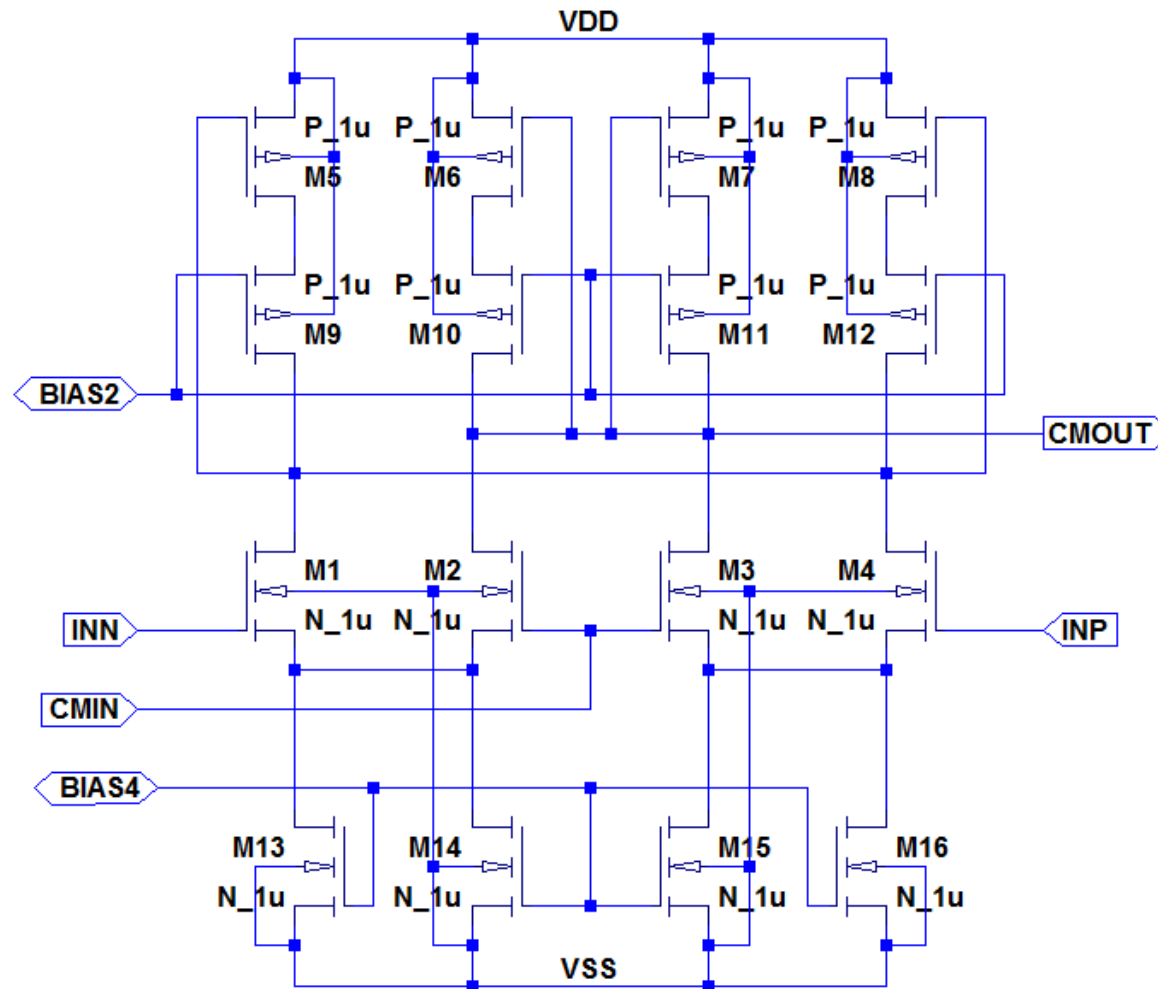

Bias

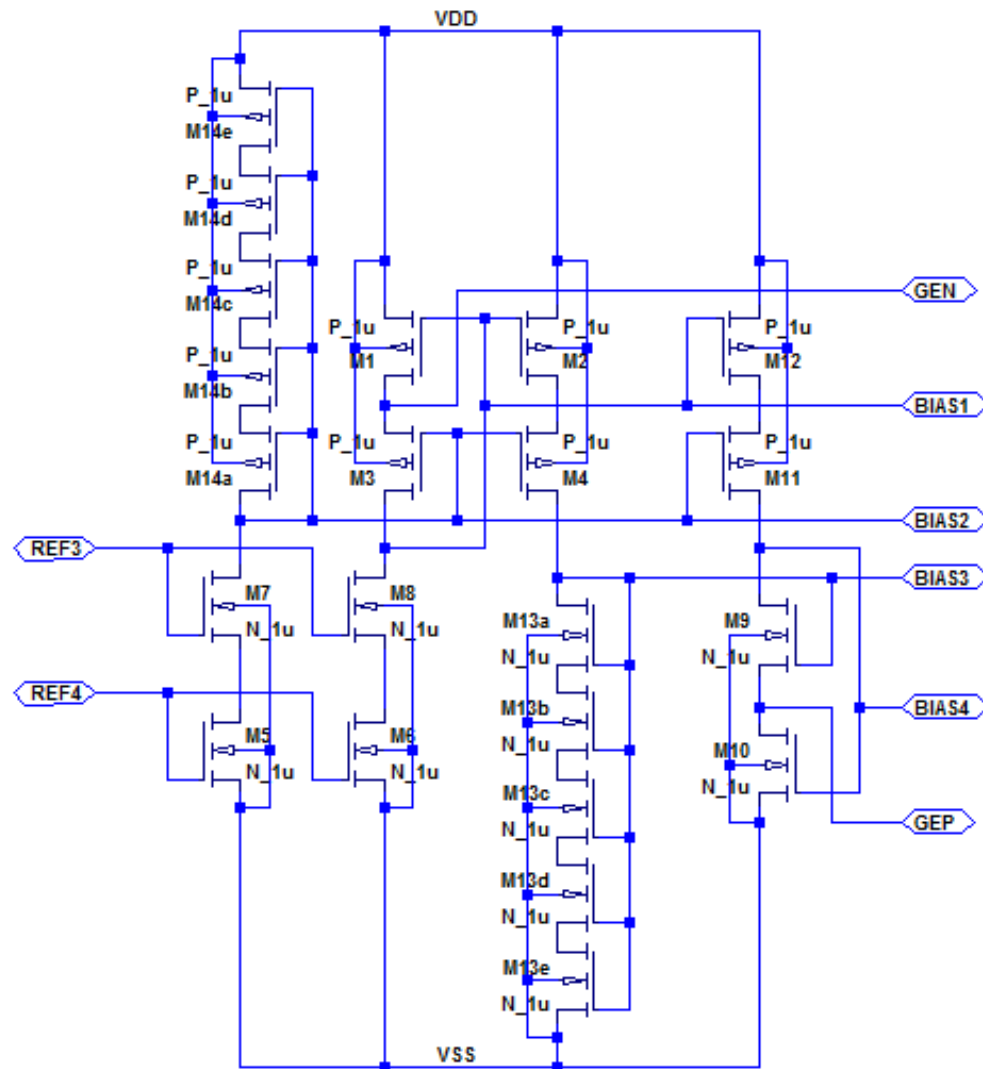

BMR

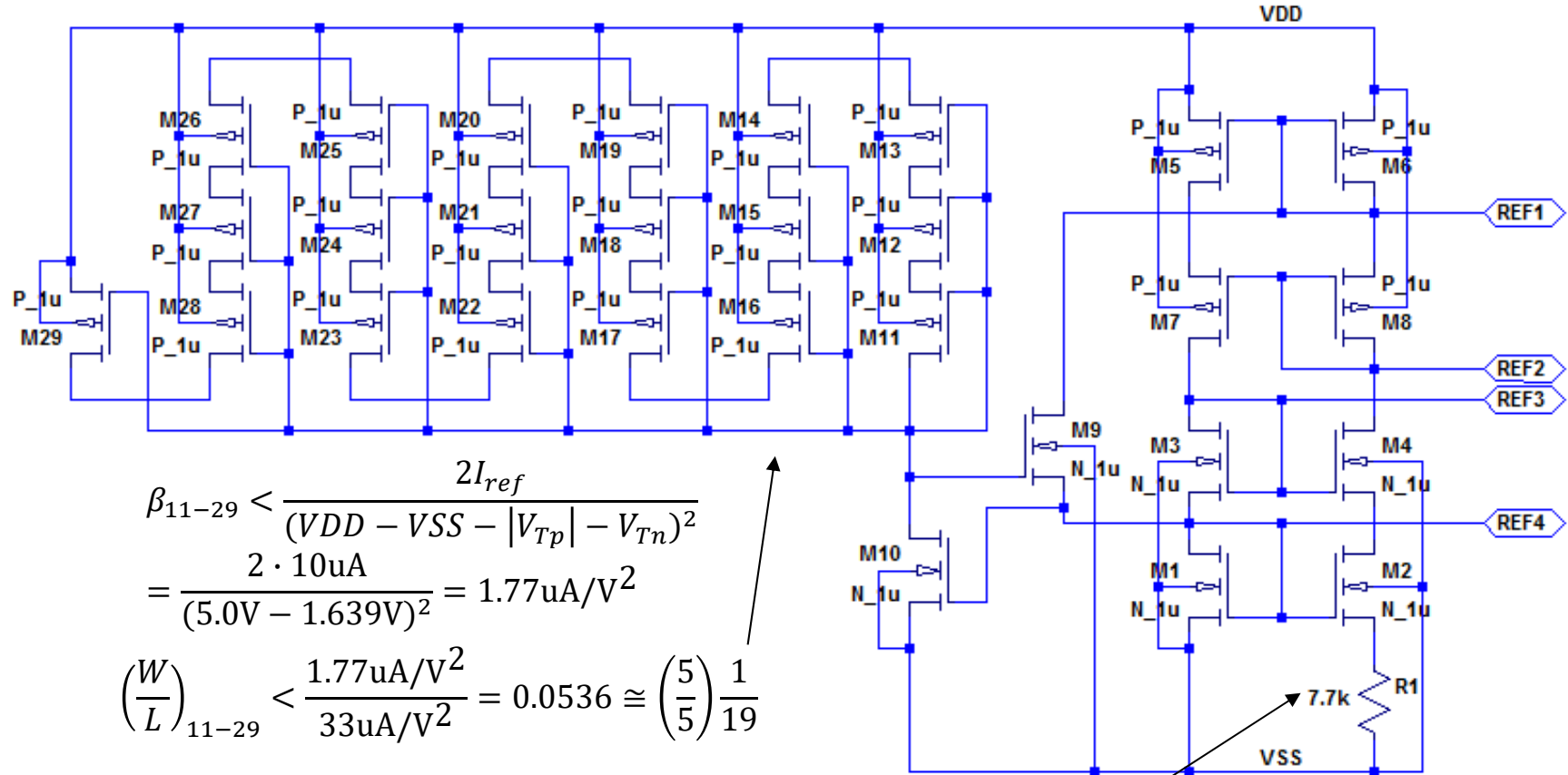

$$\beta_{11-29} < \frac{2I_{ref}}{(VDD - VSS - |V_{Tp}| - V_{Tn})^2}$$

$$= \frac{2 \cdot 10\mu A}{(5.0V - 1.639V)^2} = 1.77\mu A/V^2$$

$$\left(\frac{W}{L}\right)_{11-29} < \frac{1.77\mu A/V^2}{33\mu A/V^2} = 0.0536 \approx \left(\frac{5}{5}\right) \frac{1}{19}$$

$$R1 = \sqrt{\frac{2}{\beta_1 I_{ref}} \left(1 - \frac{1}{\sqrt{K}}\right)} = \sqrt{\frac{2}{98\mu A/V^2 \cdot 5 \cdot 10\mu A} \left(1 - \frac{1}{\sqrt{4}}\right)} = 10.1k\Omega \quad (\text{Adjusted})$$

2. Characterization

- Carry out the DC, AC, and TRAN analysis of the full-differential OPA and attach the simulation results to your report.
 - DC characteristic of $V(\text{inp})$, $V(\text{inn})$, $V(\text{outp})$, $V(\text{outn})$, $V(\text{cmfb})$, $I_d(\text{M1})$, $I_d(\text{M2})$, and $I(V1)$
 - Check the offset voltage. The systematic offset should be removed by the CMFB.
 - AC characteristic of $V(\text{outp})$ and $V(\text{outn})$
 - The step response (TRAN characteristics) of $V(\text{inp})$, $V(\text{inn})$, $V(\text{outp})$, and $V(\text{outn})$
- Fill out the blank in Table III by using your simulation results.

Table III

- The specification estimated by the simulation.

Parameter	Unit	Value	Remarks
GBP	Hz		CL = 1.0pF
A_d	dB		@ 10Hz
Phase Margin	degree		
Slew Rate	V/us		CL = 1.0pF
Total Bias Current	A		
Reference Current	A		$I_{SS}/2$